

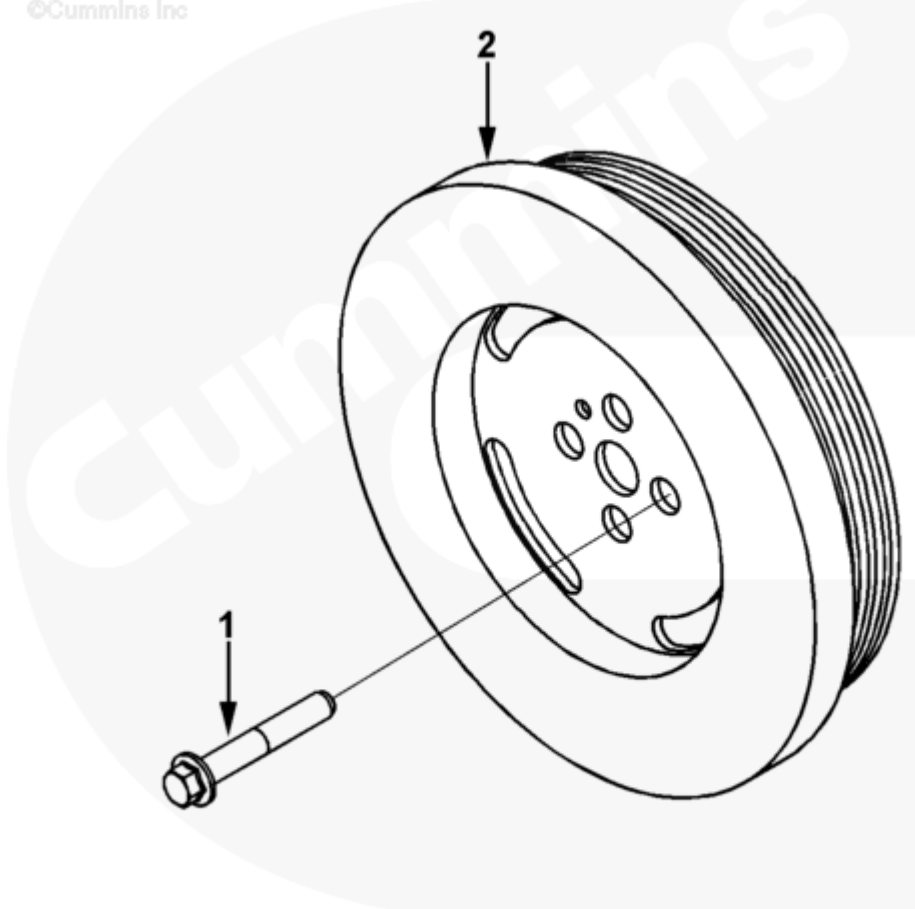

## Parts Catalog - Option Detail

Electronic Parts Catalog - Option Detail				
Option	Group	Graphic	Film Card	Date
DA9050	01.02.2	da953gg	Z	05-SEP-96
<b>Engines</b>	6C8.3, C GAS PLUS CM556, G8.3, G8.3 CM558, GTA8.3 CM558, ISC CM2150, ISC CM554, ISC CM850, ISC8.3 CM2250, ISC8.3 G CM2180 C101, ISL CM2150, ISL CM554, ISL CM850, ISL G CM2180, ISL8.9 CM2150 L110, ISL8.9 CM2880 L112, ISL9 CM2150 SN, ISL9 CM2250, ISL9 CM2350 L101, ISL9 CM2350 L111, ISLE4 CM850, L GAS PLUS CM556, L8.9, L8.9 L121, L8.9G CMOH2.0 L125B, L9 CM2350 L116B, L9 CM2350 L119B, L9 CM2350 L120C, L9 CM2350 L123B, L9.3 L105, L9.5 L117, L9N CM2380 L124B, QSC8.3 CM2250, QSC8.3 CM2880 C102, QSC8.3 CM554, QSC8.3 CM850(CM2850), QSL9 CM2250, QSL9 CM2250 L115, QSL9 CM2350 L102, QSL9 CM2350 L107, QSL9 CM2350 L118, QSL9 CM2350 L122, QSL9 CM554, QSL9 CM850(CM2850), QSL9 G CM558, QSL9 M CM2250 L106, QSL9.3 CM2880 L113			



da953gg

[SMALL](#) | [MEDIUM](#) | [LARGE](#)

Cart	Ref No	Part Number	Part Description	Required	Remarks
View My Cart					
		DA9050	Vibration Damper		MR - DAMPER, VIBRATION...(More)

					Engine Family: C Series
					Damper Pulley Effective
					Diameter (mm): 199.42
					Damper Diameter (mm): 225.00
					Damper RPM Limitation: 2201
					and Above
					Damper Type: Rubber
					Pulley Type: Cast 8 Groove
					Front PTO Provision: No
					Tach Pick-Up Provision: No
					High Inertia Damper: No
					Additional Undercut on
					Damper: No
					Engine Design Phase: Current
					Product
					Restricted Cylinders: 6
					Provision for Engine Position
					Sensor: No
					Additional Pulley Provision:
					None
					Increased Coolant Flow by 14%
					To Be Used on Applications
					Where Governed Speed or Rated
					Speed is 2201 RPM or Greater
					and FW Inertia is Less Than
					1.45 Kgm2
<input type="checkbox"/>	1	<a href="#">3906733</a>	Hexagon Flange Head Cap Screw	4	M14 x 1.50 x 35
<input type="checkbox"/>	2	<a href="#">3922559</a>	Vibration Damper	1	

